

The top half of the page features an abstract background composed of overlapping, semi-transparent blue triangles and polygons in various shades of blue, ranging from light to dark. This pattern transitions into a white background at the bottom.

Installation and Setup Guide

020-002055-01

Christie HS Series 4K

CHRISTIE®

NOTICES

COPYRIGHT AND TRADEMARKS

Copyright ©2023 Christie Digital Systems USA Inc. All rights reserved.

All brand names and product names are trademarks, registered trademarks or trade names of their respective holders.

GENERAL

Every effort has been made to ensure accuracy, however in some cases changes in the products or availability could occur which may not be reflected in this document. Christie reserves the right to make changes to specifications at any time without notice. Performance specifications are typical, but may vary depending on conditions beyond Christie's control such as maintenance of the product in proper working conditions. Performance specifications are based on information available at the time of printing. Christie makes no warranty of any kind with regard to this material, including, but not limited to, implied warranties of fitness for a particular purpose. Christie will not be liable for errors contained herein or for incidental or consequential damages in connection with the performance or use of this material. Our centers of excellence for manufacturing in Kitchener, Ontario, Canada and in Shenzhen, China are ISO 9001:2015 Quality Management System-certified.

For the most current technical documentation and office contact information, visit www.christiedigital.com.

WARRANTY

Products are warranted under Christie's standard limited warranty, the details of which are available at <https://www.christiedigital.com/help-center/warranties/> or by contacting your Christie dealer or Christie.

PREVENTATIVE MAINTENANCE

Preventative maintenance is an important part of the continued and proper operation of your product. Failure to perform maintenance as required, and in accordance with the maintenance schedule specified by Christie, will void the warranty.

REGULATORY (if applicable)

The product has been tested and found to comply with the limits for a Class A digital device, pursuant to Part 15 of the FCC Rules. These limits are designed to provide reasonable protection against harmful interference when the product is operated in a commercial environment. The product generates, uses, and can radiate radio frequency energy and, if not installed and used in accordance with the instruction manual, may cause harmful interference to radio communications. Operation of the product in a residential area is likely to cause harmful interference in which case the user will be required to correct the interference at the user's own expense. Changes or modifications not expressly approved by the party responsible for compliance could void the user's authority to operate the equipment.

CAN ICES-003 (A) / NMB-003 (A)

이 기기는 업무용 (A 급) 으로 전자파적합등록을 한 기기이오니 판매자 또는 사용자는 이점을 주의하시기 바라며, 가정 외의 지역에서 사용하는 것을 목적으로 합니다.

ENVIRONMENTAL



The product is designed and manufactured with high-quality materials and components that can be recycled and reused. This symbol  means that electrical and electronic equipment, at their end-of-life, should be disposed of separately from regular waste. Please dispose of the product appropriately and according to local regulations. In the European Union, there are separate collection systems for used electrical and electronic products.

If printing this document, consider printing only the pages you need and select the double-sided option.

Please help us to conserve the environment we live in!

NOTATION

Learn the hazard and information symbols used in the product documentation.



Danger! If not avoided, the following could result in death or serious injury.



Warning! If not avoided, the following could result in death or serious injury.



Caution! If not avoided, the following could result in minor or moderate injury.



Notice. If not avoided, the following may result in equipment or property damage.

Content

Introduction	5
Safety and warning guidelines	5
AC/power precautions	6
Installation safety and warning guidelines	6
Laser safety precautions	7
Light intensity hazard distance	7
Product labels	11
Projector overview	13
Contact your dealer	13
Key features	13
How the projector works	14
List of components	14
Product documentation	15
Related documentation	15
Technical support	16
Installation and setup	17
Site requirements	17
Physical operating environment	17
Power connection	17
Physical specifications	17
Projector components	18
Front view	18
Rear view	18
Left view	19
Right view	19
Built-in keypad	20
Input/output (I/O) panel	21
IR remote keypad	22
Positioning the display	24
Installing the ceiling mount	25
Leveling the projector	25
Installing the projector lens	26
Calibrating the lens motor	26

Removing the projection lens 27

Removing and installing the fuse 28

Cleaning or installing the filter 29

Connecting to AC power 30

Turning on the projector 31

Turning off the projector 31

LED status indicator 32

 Status LED 32

 Shutter LED 32

Setting up the projector lens 33

 Adjusting the zoom and focus 33

 Adjusting lens position 33

 Resetting the lens to home position 33

 Calculating the lens offset 34

 Adjusting boresight 36

Connecting to devices 38

 Connecting to a computer 38

 Connecting to video equipment 39

Signal connectivity specifications 40

 HDMI video formats 40

 DisplayPort video formats 42

 HDBaseT video formats 43

 12G-SDI video formats 44

 Picture-in-picture/picture-by-picture (PIP/PBP) compatibility 44

Regulatory 45

 Safety 45

 Laser safety 45

 Electro-magnetic compatibility 45

 Emissions 45

 Immunity 46

 California law on security 46

 Environmental 46

Introduction

This manual is intended for Christie qualified installers and trained operators of HS Series 4K projection systems.

For complete HS Series 4K product documentation and technical support, go to www.christiedigital.com.

Safety and warning guidelines

Read all safety and warning guidelines before installing or operating the projector. This projector must be operated in an environment that meets the operating range specification. Use only the attachments and/or accessories recommended by Christie. Use of others may result in the risk of fire, shock, or personal injury. This projector is intended for use in a non-cinema environment.



Warning! If not avoided, the following could result in death or serious injury.

- Do not expose the product to moisture.
- Do not operate the product without all of its covers in place.
- This product must be installed within a restricted access location not accessible by the general public.
- Only personnel who are trained on the precautions for the restricted access location can be granted entry to the area.
- FIRE HAZARD! Keep hands, clothes, and all combustible material away from the concentrated light beam of the projector.
- TRIP OR FIRE HAZARD! Position all cables where they cannot contact hot surfaces, be pulled, be tripped over, or damaged by persons walking on or objects rolling over the cables.
- SHOCK HAZARD! Disconnect the product from AC before installing, moving, servicing, cleaning, removing components, or opening any enclosure.
- A minimum of two people or appropriately rated lift equipment is required to safely lift, install, or move the product.
- OPTICAL RADIATION HAZARD! Disconnect the power plug from the AC outlet if the product is not being used for an extended period of time.
- Do not allow anything to rest on the power cord.
- Always provide proper ventilation for the product to prevent overheating.



Caution! If not avoided, the following could result in minor or moderate injury.

- Only Christie qualified technicians are permitted to open product enclosures.
- All procedures must be performed by Christie qualified technicians.



Notice. If not avoided, the following may result in equipment or property damage.

- Always use a lens plug when installing or moving the product to prevent contaminants from entering the product.
- Only use cleaning solutions recommended by Christie. All other cleaning solutions may cause product damage and will void the warranty.

AC/power precautions

Read all AC/power precautions before installing or operating the projector.



Warning! If not avoided, the following could result in death or serious injury.

- FIRE HAZARD! Do not use a power cord, harness, or cable that appears damaged.
- FIRE OR SHOCK HAZARD! Do not overload power outlets and extension cords.
- SHOCK HAZARD! Only use the AC power cord provided with the product or recommended by Christie.
- FIRE AND SHOCK HAZARD! Do not attempt operation unless the power cord, power socket, and power plug meet the appropriate local rating standards.
- SHOCK HAZARD! Do not attempt operation if the AC supply is not within the specified voltage and current, as specified on the license label.
- SHOCK HAZARD! The AC power cord must be inserted into an outlet with grounding.
- SHOCK HAZARD! Disconnect the product from AC before installing, moving, servicing, cleaning, removing components, or opening any enclosure.
- Install the product near an easily accessible AC receptacle.

Installation safety and warning guidelines

Read all installation safety and warning guidelines before installing the projector.



Warning! If not avoided, the following could result in death or serious injury.

- High leakage current present when connected to IT power systems.



Caution! If not avoided, the following could result in minor or moderate injury.

- ELECTRICAL and BURN HAZARD! Use caution when accessing internal components.
- Only Christie qualified technicians are authorized to use the tools provided in the toolbox.

Laser safety precautions

Read all safety and warning guidelines before installing or operating the projector.



Warning! If not avoided, the following could result in death or serious injury.

- **LASER RADIATION HAZARD!** This projector has a built-in Class 4 Laser module. Never attempt to disassemble or modify the laser module.
- Any operation or adjustment not specifically instructed in the User manual creates the risk of hazardous laser radiation exposure.
- Do not operate the product without all of its covers in place.
- Do not look directly into the lens when the light source is on. The extremely high brightness can cause permanent eye damage.
- Only Christie-qualified technicians who are knowledgeable about the hazards associated with laser use, high-voltage, and high temperatures generated by the product are authorized to assemble, install, and service the Christie Laser Projection System.
- Do not look directly into the lens when the light source is on. The extremely high brightness can cause permanent eye damage. Class 1 laser product of IEC/EN 60825-1:2014 and Risk Group 2 according to IEC 62471-5:2015.
- Install the product so users and the audience cannot enter the restricted area at eye level.
- Install the product out of reach.
- **LASER RADIATION!** Do not look directly into the laser beam of the remote.
- Complies with 21 CFR 1040.10 and 1040.11 except for conformance as a Risk Group 2 LIP as defined in IEC 62471-5:Ed. 1.0. For more information see Laser Notice No. 57, dated May 8, 2019. IEC 60825-1:2014: CLASS 1 LASER PRODUCT - RISK GROUP 2.
- For 4K13-HS, 4K13A-HS, 4K22-HS, and 4K22A-HS, no direct exposure to the beam shall be permitted, RG3 IEC 62471-5 when installed with 140- 110103-XX lens (throw ratio 1.5-2.0) or of a higher Throw ratio lens.

Light intensity hazard distance

This projector has been classified as Risk Group 3 according to the IEC 62471-5:2015 standard due to possible hazardous optical and thermal radiation being emitted.



Warning! If not avoided, the following could result in death or serious injury.

- **PERMANENT/TEMPORARY BLINDNESS HAZARD!** No direct exposure to the beam must be permitted.
- **PERMANENT/TEMPORARY BLINDNESS HAZARD!** Operators must control access to the beam within the hazard distance or install the product preventing potential exposure of the spectators' eyes from being in the hazard distance. Hazard zone shall be no lower than 3.0 meters above the floor. In addition, horizontal clearance to the hazard zone shall be a minimum 2.5 meters.
- **EXTREME BRIGHTNESS!** Do not place reflective objects in the product light path.

The following diagram shows the zones for optical and skin hazard distances:

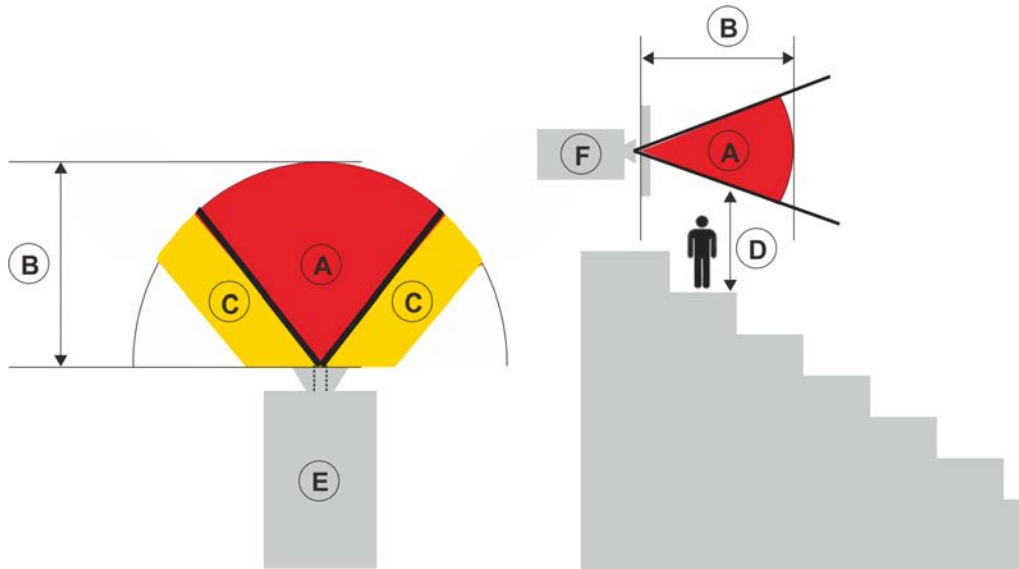

- A—Hazard zone. The region of space where the projection light from the laser-illuminated projector is above emission limits for Risk Group 2. The light intensity may cause eye damage after a momentary or brief exposure (before a person can avert his or her eyes away from the light source). The light may cause skin burns to occur.
- B—Hazard distance. Operators must control access to the beam within the hazard distance or install the product preventing potential exposure of the spectators' eyes from being in the hazard distance.
- C—No access zone. Horizontal clearance of the no access zone must be a minimum of 2.5 meters.
- D—Vertical distance to hazard zone. The hazard zone must be no lower than 3.0 meters above the floor.
- E—Represents the top view of the projector.
- F—Represents the side view of the projector.

The following table lists the hazard distance for the Christie projector lens with the zoom adjusted to its most hazardous position.

4K13-HS/4K13A-HS

Projection lens	Part number	Hazard distance (m)	Category
0.38:1 Ultra short throw lens	140-142108-XX	N/A	RG2
0.65-0.75:1 Zoom lens	140-144100-XX	N/A	RG2
1.02-1.36:1 Zoom lens	140-115108-XX	N/A	RG2
1.2-1.5:1 Zoom lens	140-109101-XX	N/A	RG2
1.5-2.0:1 Zoom lens	140-110103-XX	N/A	RG2
2.0-4.0:1 Zoom lens	140-111104-XX	1.7	RG3
4.0-7.2:1 Zoom lens	140-116109-XX	4.1	RG3
7.2-10.8:1 Zoom lens	140-145101-XX	5.4	RG3

4K22-HS/4K22A-HS

Projection lens	Part number	Hazard distance (m)	Category
0.38:1 Ultra short throw lens	140-142108-XX	N/A	RG2
0.65-0.75:1 Zoom lens	140-144100-XX	N/A	RG2
1.02-1.36:1 Zoom lens	140-115108-XX	N/A	RG2
1.2-1.5:1 Zoom lens	140-109101-XX	N/A	RG2
1.5-2.0:1 Zoom lens	140-110103-XX	1.1	RG3
2.0-4.0:1 Zoom lens	140-111104-XX	2.0	RG3
4.0-7.2:1 Zoom lens	140-116109-XX	4.5	RG3
7.2-10.8:1 Zoom lens	140-145101-XX	8.7	RG3

For installations in the United States

The following must be in place for laser-illuminated projector installations in the United States:















- Any human access to the hazard zone, if applicable, must be restricted by barriers to enforce the no access zone.
- Permanent show installations containing Risk Group 3 laser-illuminated projectors must meet the following conditions:
 - Installed by Christie or by Christie-authorized and trained installers. Refer to the EXTERNAL - Laser safety awareness training (Course code: CS-ELSA-01) on the <http://www.christieuniversity.com> site.
 - Performed according to instructions provided by Christie.
 - Ensure the projection system is securely mounted or immobilized to prevent unintended movement or misalignment of the projections.
- Temporary show installations containing Risk Group 3 laser-illuminated projectors may be installed by Christie or sold or leased only to valid laser light show variance holders (laser light show manufacturers) for image projection applications. Such manufacturers may currently hold a valid variance for production of Class IIIb and IV laser light shows and/or for incorporation of the Risk Group 3 laser-illuminated projectors into their shows. This requirement applies also to dealers and distributors of these laser-illuminated projectors.
- The Christie Laser Projection System Installation Checklist must be fully completed after the installation and sent to lasercompliance@christiedigital.com. A copy can remain on-site. This checklist can be found as a separate document in the accessory box with the manual.
- Certain US states have additional laser regulatory requirements. Go to www.christiedigital.com for further information.

Product labels

Learn about the labels that may be used on the product. Labels on your product may be yellow or black and white.

General hazards

Hazard warnings also apply to accessories once they are installed in a Christie product that is connected to power.

Fire and Shock Hazard	
 	<p>To prevent fire or shock hazards, do not expose this product to rain or moisture.</p> <p>Do not alter the power plug, overload the power outlet, or use it with extension Cords.</p> <p>Do not remove the product enclosure.</p> <p>Only Christie qualified technicians are authorized to service the product.</p>
Electrical Hazard	
	<p>Risk of electric shock.</p> <p>Do not remove the product enclosure.</p> <p>Only Christie qualified technicians are authorized to service the product.</p>
	<p>General hazard.</p>
	<p>Electric shock hazard. To avoid personal injury, disconnect all power sources before performing maintenance or service.</p>
	<p>Electrocution hazard. To avoid personal injury, always disconnect all power sources before performing maintenance or service procedures.</p>
	<p>Fire hazard. To avoid personal injury and property damage, follow the instructions provided in this document.</p>
	<p>Hot surface hazard. To avoid personal injury, allow the product to cool for the recommended cool down time before performing maintenance or service.</p>
	<p>Burn hazard. To avoid personal injury, allow the product to cool for the recommended cool down time before performing maintenance or service.</p>
	<p>Bright light hazard. To avoid personal injury, never look directly at the light source.</p>
	<p>Moving parts hazard. To avoid personal injury, keep hands clear and loose clothing tied back.</p>
	<p>Fan hazard. To avoid personal injury, keep hands clear and loose clothing tied back. Always disconnect all power sources before performing maintenance or service procedures.</p>
	<p>Voltage hazard. To avoid personal injury, always disconnect all power sources before performing maintenance or service procedures.</p>
	<p>Not for household use.</p>

Mandatory action



Consult the service manual.



Disconnect all power sources before performing maintenance or service procedures.

Electrical labels



Indicates the presence of an earth ground.

Laser labels



This projector has been classified as Class 1 Laser Product-Risk Group 2 according to the IEC 60825-1:2014 and IEC 62471- 5:2015 standard.

Indicates a light hazard. Do not look directly into the lens. The extreme high brightness can cause permanent eye damage.

Class 1 Laser Product-Risk Group 2 according to Class 1 IEC 60825-1:2014 and IEC 62471-5:2015.



Mount above the heads of children. When within 1 m of the product, avoid eye exposure to avoid temporary or permanent eye damage.

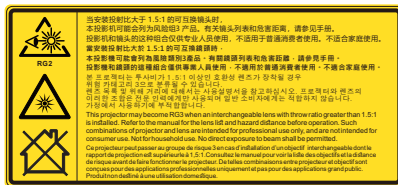

This projector may become RG3 when an interchangeable lens with throw ratio greater than 1.5:1 is installed.

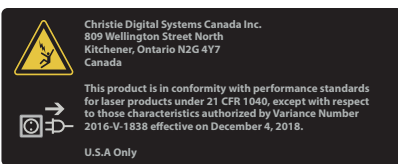

FDA laser variance (US projectors only).

Additional safety hazard



Do not look directly into the lens. The extremely high brightness can cause permanent eye damage.

Projector overview

The HS Series 4K is a high brightness, high-resolution video graphics one-chip laser-based projector. The projector is available in 4K resolution and uses Digital Light Processing (DLP™) technology from Texas Instruments. It is primarily designed for fixed installation and secondary applications including rental-staging and LBE (Location Based Entertainment). This product is used for professional applications and is not for domestic use.

Contact your dealer

Record the information about your projector and keep this information with your records to assist with the servicing of your projector. If you encounter a problem with your Christie projector, contact your dealer.

Purchase record	
Dealer:	
Dealer or Christie Sales/Service contact phone number:	
Projector serial number: The serial number can be found on the license label	
Purchase date:	
Installation date:	

Ethernet settings	
Default gateway:	
Projector IP address:	
Subnet mask:	

Key features

- High brightness performance:
 - 19,000 ANSI lumens typical for 4K22-HS, and 4K22A-HS
 - 12,500 ANSI lumens typical for 4K13-HS, and 4K13A-HS
- High picture quality with superb brightness performance
- Lens suite options for installation flexibility
- Powered lens adjustment with lens memory function
- Projection lens compatibility:
 - Horizontal offset ranges with half image size: up to ±50%
 - Vertical offset ranges with half image size: up to ±140%
Measurements comply with industry standards where offset is calculated as a ratio of the number of pixels shifted up or down to half image size.

- 360 degrees projection
- 3D blending and auto warping
- Supports fog filter as an optional accessory
- Full HD 3D technology with frame sequential up to 120 Hz
- Christie Twist™ and Mystique™ allows for easy and quick blending and warping. Support for Mystique™ camera based alignment system (sold separately)
- A wide range of connectivity including HDMI, HDBaseT, and 3D inputs
- Integrated HDBaseT solution supports 4K video streaming through RJ45
- Wireless desktop display using wireless dongle (optional)
- SNMP traps and email notifications
- 10-bit image processor electronics with modular design
- All video formats can be resized to full screen either horizontally or vertically while maintaining aspect ratio.
- The projector can be operated using any of the following:
 - The built-in keypad, the infrared (IR) remote keypad, a wired remote keypad, or a PC/ device using serial communications (Ethernet or RS232)
 - A web page using Ethernet, or from a PC or device using a wireless USB dongle (optional)

How the projector works

The HS series 4K projector accepts a variety of input signals for a wide range of commercial projection applications.

Designed with blue solid-state illumination light sources and phosphor technology, the red, green and blue color elements are modulated by one Digital Micromirror Device (DMD) panel responding to incoming data streams of digitized red, green, and blue color information. As these digital streams flow from the source, light from the responding on pixels of the DMD panel is reflected, converged, and then projected to the screen through projection lenses, where all pixel reflections are superimposed in sharp full-color images.

List of components

This projector comes with all the items listed below. Check to make sure your package is complete. If anything is missing, contact your dealer.

- IR remote keypad
- Product Safety Guide

Product documentation

For installation, setup, and user information, see the product documentation available on the Christie Digital Systems USA Inc. website at www.christiedigital.com. Read all instructions before using or servicing this product.

1. Access the documentation from the Christie website:
 - Go to this URL: <http://bit.ly/2JtghsE> or <https://www.christiedigital.com/en-us/business/products/projectors/1-chip-dlp/hs-series>
 - Scan the QR code using a QR code reader app on a smartphone or tablet.



2. On the product page, select the model and switch to the **Downloads** tab.

Related documentation

Additional information on the projector is available in the following documents.

- *HS Series 4K Product Safety Guide (P/N: 020-002052-XX)*
- *HS Series 4K User Manual (P/N: 020-002053-XX)*
- *HS Series 4K Service Manual (P/N: 020-002054-XX)*
- *HS Series 4K Serial Commands Technical Reference (P/N: 020-103737-XX)*
- *Twist User Guide (P/N: 020-101380-XX)*
- *Mystique Operate Instruction Sheet (P/N: 020-102382-XX)*

Technical support

Technical support for Christie Enterprise products is available at:

- North and South America: +1-800-221-8025 or Support.Americas@christiedigital.com
- Europe, Middle East, and Africa: +44 (0) 1189 778111 or Support.EMEA@christiedigital.com
- Asia Pacific (support.apac@christiedigital.com):
 - Australia: +61 (0)7 3624 4888 or tech-Australia@christiedigital.com
 - China: +86 10 6561 0240 or tech-supportChina@christiedigital.com
 - India: +91 (80) 6708 9999 or tech-India@christiedigital.com
 - Japan: 81-3-3599-7481
 - Singapore: +65 6877-8737 or tech-Singapore@christiedigital.com
 - South Korea: +82 2 702 1601 or tech-Korea@christiedigital.com
- Christie Professional Services: +1-800-550-3061 or NOC@christiedigital.com

Installation and setup

Learn how to install, connect, and optimize the projector display.

Site requirements

To safely install and operate the projector, the installation location must have restricted access for authorized personnel only and meet these minimum requirements.

Physical operating environment

Provides specifications for the operating environment.

- Ambient temperature (operating): 0 to 40°C (32 to 104°F) up to 762 m (2500 feet)
- Humidity (non-condensing): 10% to 85% RH
- Operating altitude: 3048 m (10,000 feet) at 0 to 30°C (32 to 86°F) ambient temperature

Power connection

The projector uses an AC power system that allows the projector to operate at full brightness with a power supply ranging from 100 to 240 VAC, depending on the models and regions. Operating the device outside of the voltage range may cause unsatisfactory operation or damage to the projector.

Christie recommends a 20 A rated wall breaker for the installation. To ensure safe operation, only use the AC power cord provided with the product or recommended by Christie. See [Connecting to AC power](#) on page 30 for further information on the power requirements.

Physical specifications

Learn the dimensions and weight of the projector before installation.

- Projection size, excluding lens, feet (L x W x H): 677 x 596 x 203 mm (26.6 x 23.5 x 8.0 inches)
- Shipping size, without lens (L x W x H): 965 x 795 x 365 mm (38 x 31.3 x 14.4 inches)
- Weight, without lens: 43.5 kg (95.9 lbs)
- Shipping weight, without lens: 56.4 kg (124.3 lbs)

Projector components

Identify the main components of the projector.

Front view

Identify the main components on the front of the projector.

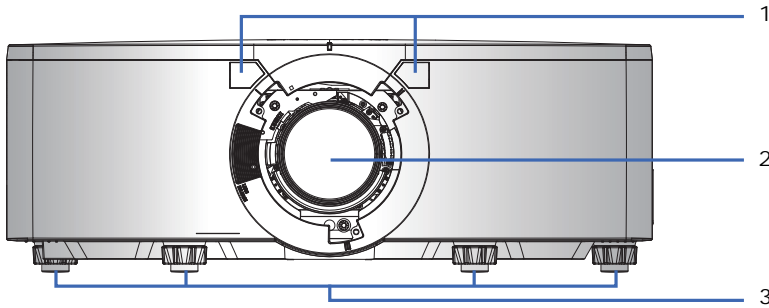

ID	Part name	Description
1	Front IR sensors	Receives signals from the IR remote keypad. Keep the signal path to the sensor unobstructed for uninterrupted communication with the projector.
2	Projection lens	Allows automated lens control and adjustment: vertical and horizontal offsets, zoom, and focus.
3	Adjustable feet	Raises or lowers the feet to level the projector.

Rear view

Identify the main components on the rear of the projector.

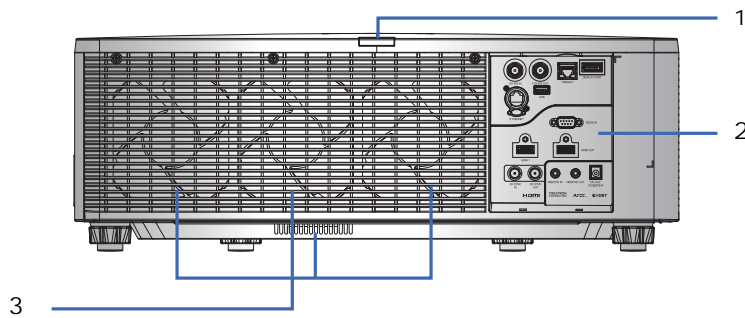

ID	Part name	Description
1	Rear IR sensor	Receives signals from the IR remote keypad. Keep the signal path unobstructed for uninterrupted communication with the projector.
2	Input/Output (I/O) panel	Connects the projector to external devices.

ID	Part name	Description
3	Cooling air vents (exhaust)	Provides cooling to the projector. Keep these vents unobstructed to prevent the projector from overheating.

Left view

Identify the main components on the left side of the projector.

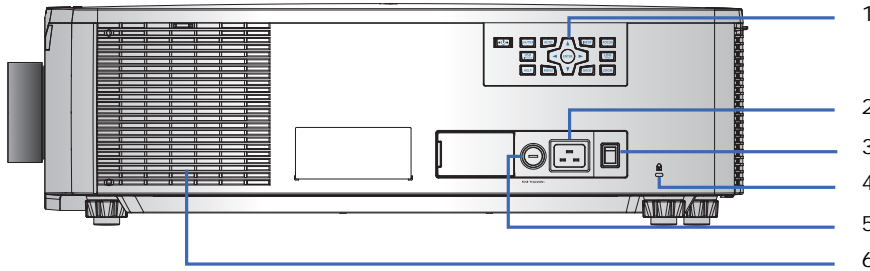

ID	Part name	Description
1	Built-in keypad	Controls the projector.
2	AC input	Connects to the supplied power adapter.
3	Power button	Powers the projector on or off.
4	Kensington lock	Secures the projector to counter tops, tables, and so on.
5	Fuse	<ul style="list-style-type: none"> • 4K13-HS/4K13A-HS: T15A/250VAC • 4K22-HS/4K22A-HS: T20A/250VAC
6	Cooling air vents (intake)	Provides cooling to the projector. Keep these vents unobstructed to prevent the projector from overheating.

Right view

Identify the main component on the right side of the projector.

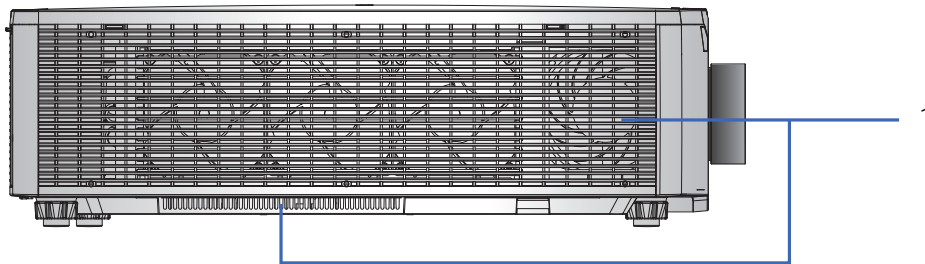

ID	Part name	Description
1	Cooling air vents (intake)	Provides cooling to the projector. Keep these vents unobstructed to prevent the projector from overheating.

Built-in keypad

The built-in keypad controls the projector.

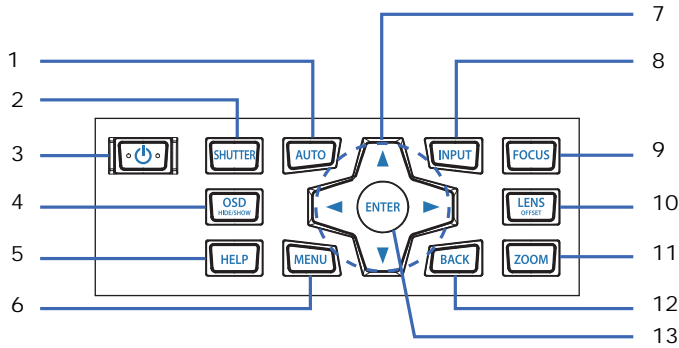

ID	Button	Description
1	AUTO	Automatically optimizes an image.
2	SHUTTER	Displays or blanks the video image.
3	POWER	Turns the projector on or off.
4	OSD HIDE/SHOW	Hides or shows the on-screen display (OSD) menus.
5	HELP	Displays the instructions for source connection.
6	MENU	Displays the menus.
7	Arrow Keys	Adjusts a setting up or down, or navigate within a menu.
8	INPUT	Selects an input for the main or picture in picture/picture by picture (PIP/PBP) image.
9	FOCUS	Adjusts the focus.
10	LENS OFFSET	Adjusts the lens vertical or horizontal offset setting.
11	ZOOM	Adjusts the zoom.
12	BACK	Returns to the previous level or exits the menus if at top level.
13	ENTER	Confirms the item selection.

Input/output (I/O) panel

Identify the components of the Input/Output (I/O) panel.

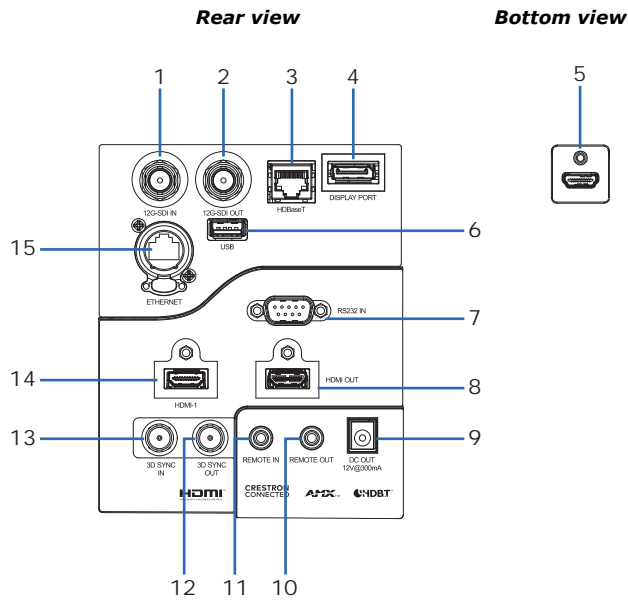

ID	Connector name	ID	Connector name
1	12G-SDI IN	9	DC OUT
2	12G-SDI OUT	10	REMOTE OUT
3	HDBaseT	11	REMOTE IN
4	DISPLAY PORT	12	3D SYNC OUT
5	HDMI-2	13	3D SYNC IN
6	USB (5 V/500 mA)	14	HDMI-1
7	RS232 IN	15	ETHERNET (10/100 Mbps)
8	HDMI OUT		

IR remote keypad

The IR remote keypad communicates with the projector by way of wireless communications.

If you choose to use a cable, not supplied, it must be 20 m (65.6 feet) or less. If the length of cable exceeds 20 m (65.6 feet), the IR remote keypad may not work correctly.

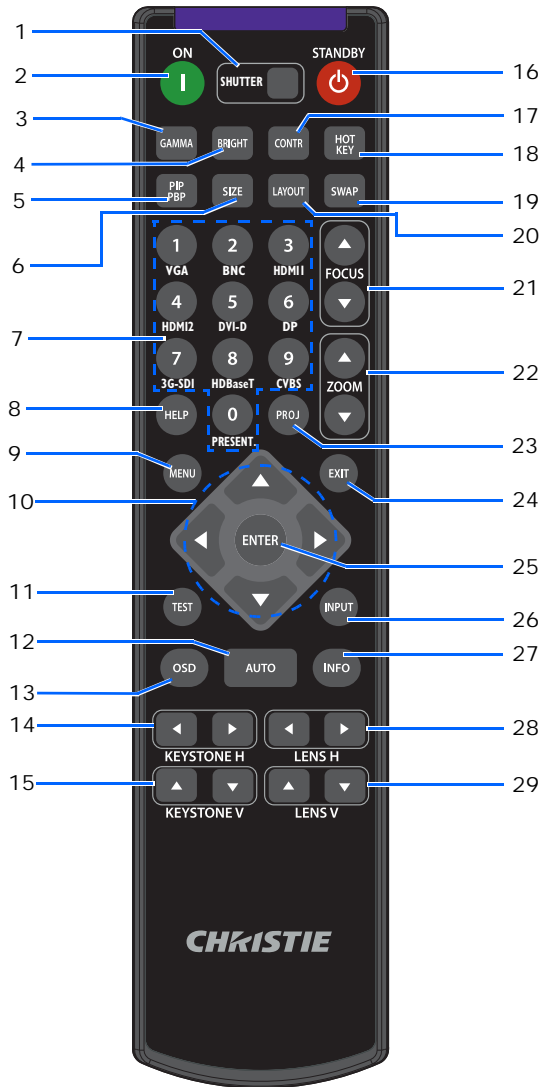

ID	Button	Description
1	SHUTTER	Displays or blanks the video image.
2	ON	Turns the projector on.
3	GAMMA	Adjusts the mid-range levels.
4	BRIGHT	Adjusts the amount of light in the image.

ID	Button	Description
5	PIP PBP	Turns picture-in-picture/picture-by-picture (PIP/PBP) on or off.
6	SIZE	Adjusts the PIP/PBP size.
7	Number Keys	Enter a number, such as a channel, value, and so on. The on-screen display (OSD) indicates if a function is not supported.
8	HELP	Displays the instructions for source connection.
9	MENU	Displays the menus.
10	Arrow Keys	Adjusts a setting up or down to navigate within a menu.
11	TEST	Displays a test pattern.
12	AUTO	Automatically optimizes an image.
13	OSD	Hides or shows OSD menus.
14	KEYSTONE H	Adjusts the horizontal keystone.
15	KEYSTONE V	Adjusts the vertical keystone.
16	STANDBY	Turns the projector off.
17	CONTR	Adjusts the difference between dark and light.
18	HOT KEY	Selects your preset key quickly.
19	SWAP	Swaps the main and PIP/PBP images.
20	LAYOUT	Adjusts the PIP/PBP layout.
21	FOCUS	Adjusts the focus to improve image clarity as required.
22	ZOOM	Adjusts the zoom to achieve a required image size.
23	PROJ	Changes the IR remote keypad ID. <ul style="list-style-type: none"> • To assign an ID, select PROJ + <1 to 9>. • To return to the universal IR remote ID, select PROJ + 0.
24	EXIT	Returns to the previous level or exits menus if at the top level.
25	ENTER	Selects a highlighted menu item, or changes or accepts a value.
26	INPUT	Selects an input for the main or PIP/PBP image.
27	INFO	Displays the projector information.
28	LENS H	Adjusts the position of the image horizontally.
29	LENS V	Adjusts the position of the image vertically.

Positioning the display

When you select a position for the projector, consider the size and shape of your screen, the location of your power outlets, and the distance between the projector and the rest of your equipment. Follow these general guidelines:

- Position the projector on a flat surface at a right angle to the screen. The projector (with the standard lens) must be at least 1.6 m (5.2 feet) from the projection screen.
- Position the projector to the required distance from the screen. The distance from the lens of the projector to the screen, the zoom setting, and the video format determine the size of the projected image.
- Determine the lens throw ratio.
For more information detailing the throw ratio for each lens, refer to the *HS Series 4K Lens Throw Ratios Technical Reference (P/N: 020-103738-XX)*.
- 360 degree free orientation operation

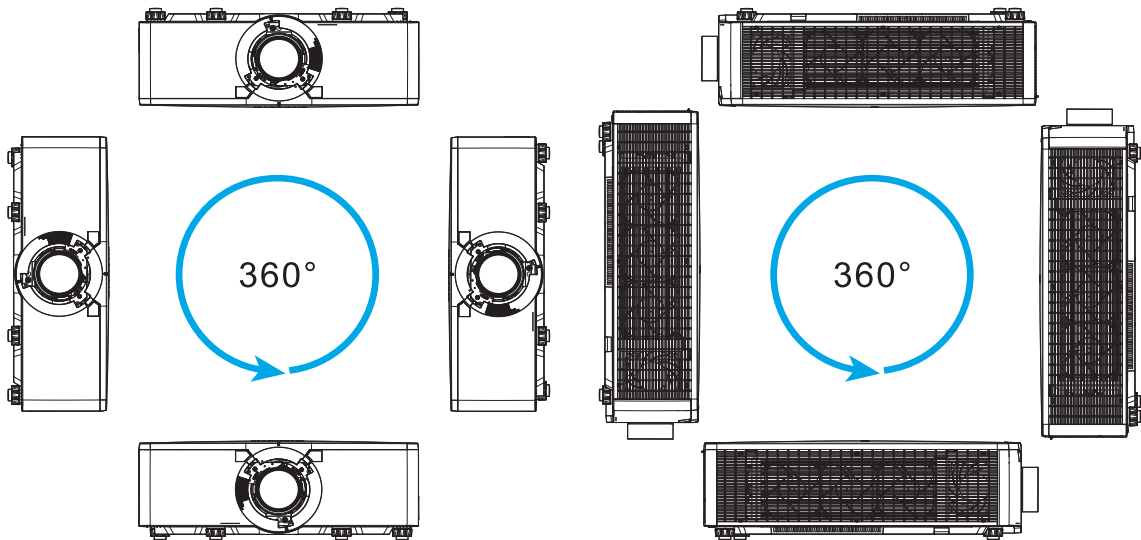

When installing the projector in portrait orientation, Christie recommends the built in keypad and power inputs face upwards. This allows access to the built in keypad and power connections during operation.

Installing the ceiling mount

Mount the projector with a Christie-approved mount or rigging frame, such as Christie One Mount Plus (P/N: 140-117100-XX) or Christie One Aluminum Rigging Frame (P/N: 140-137102-XX), using the four mounting points on the underside of the projector.



Warning! If not avoided, the following could result in death or serious injury.

- When not mounted properly, the projector may fall.
- The warranty on this projector does not cover damage caused by the use of a non-recommended ceiling mount kit or installation of the ceiling mount kit in an improper location.

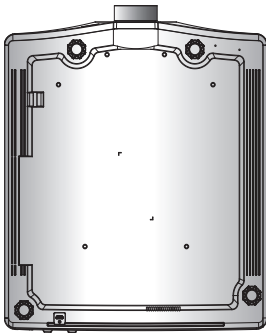

Refer to the installation instructions and safety guidelines provided in the kit, such as Christie One Mount Plus (P/N: 140-117100-XX) or Christie One Aluminum Rigging Frame (P/N: 140-137102-XX).

Leveling the projector

To adjust the vertical position of the projector, turn in or out of the adjustable feet on the bottom of the projector.

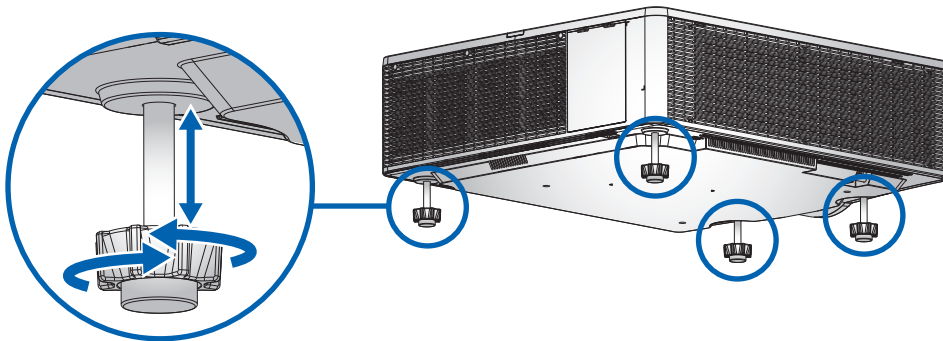

Installing the projector lens



Warning! If not avoided, the following could result in death or serious injury.

- Turn off the projector and remove the power cord, before installing or replacing a lens.

Only use the lens compatible with Christie HS Series 4K projectors.

1. Remove the dusk cover from the lens opening.
2. Release the screw on the lens release button.

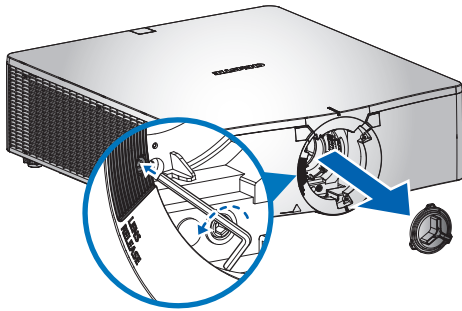

3. Align the top of the lens with the red marker on front cover.

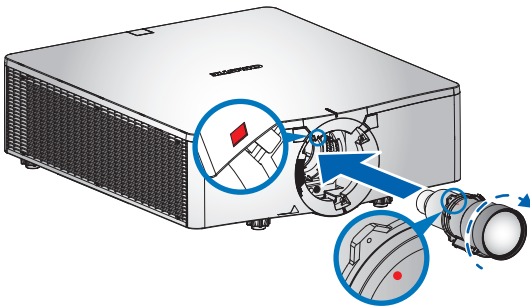

4. Insert the lens into the projector and turn it clockwise until you hear a clicking sound.



- When handling the projector after lens installation, make sure the front lens cap is placed on the lens to protect the lens surface from potential damage.
- When carrying or moving the projector, do not handle by the lens. This may damage the lens, the chassis, or other mechanical parts within the projector.

Calibrating the lens motor

Ensure the lens motor is calibrated before using the projector. Failure to calibrate the lens motor properly may cause following implications.

- Inability to use the full range of the lens motor.
- Lens motor traveling beyond the lens shifting range.

- Damage to the projector.

Calibrate the lens motors when any of the following conditions are met:

- After a lens change.
- After the projector is moved.
- After any manual adjustment made to the zoom or focus.

To calibrate the lens motor:

1. Select **LENS** on keypad or **LENS H/LENS V** on remote control.
You can also select **Menu > Configuration > Lens Settings > Lens Calibration**.
2. Select **ENTER**.
3. To start the lens calibration, select **OK**.

Removing the projection lens



Notice. If not avoided, the following may result in equipment or property damage.

- Always use a lens plug when installing or moving the product. This prevents contaminants from entering the product.
- Do not operate the product without a lens installed.

To safely remove the projection lens, complete the following steps.

1. Center the lens while the projector is switched on by selecting the **LENS H** or **LENS V** button and then selecting **ENTER**.
Make sure the lens is at or near its center position. Attempting to remove the lens with a large offset may cause damage to the lens assembly.
2. Turn off the projector.
3. Allow the projector to cool down into standby mode before replacing the lens.
4. After the projector has cooled down and prior to replacing the lens, remove the power cord.
5. Push in and hold the lens release button.
6. Turn the lens counterclockwise by a quarter to release the lens.
7. Gently pull the lens out of the lens holder.

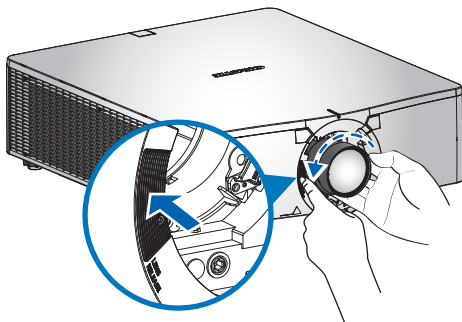

Removing and installing the fuse

To remove and install the fuse, complete the following steps.

1. Turn the projector off.
2. Remove the screw on the fuse with a flat-head screwdriver.
3. Remove the fuse and replace it with the new one.

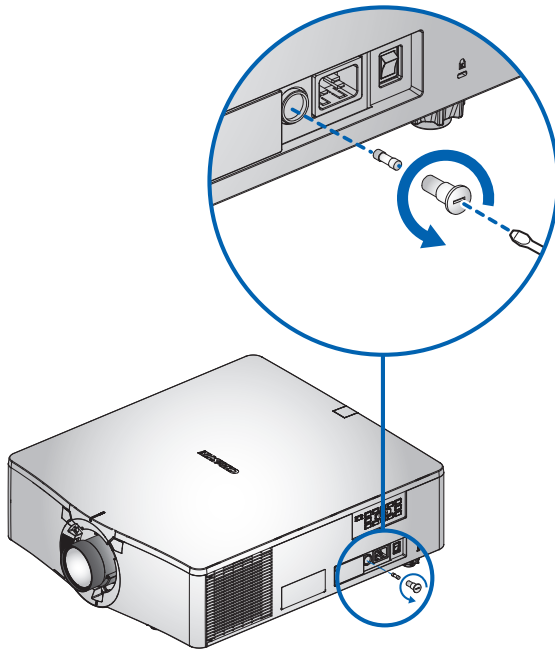

Cleaning or installing the filter

Regularly clean or replace the filters in the projector to ensure dust and other foreign materials are kept out of the projector.

1. Turn off the projector.
2. Remove the screws on the filter cover.

Left side filter

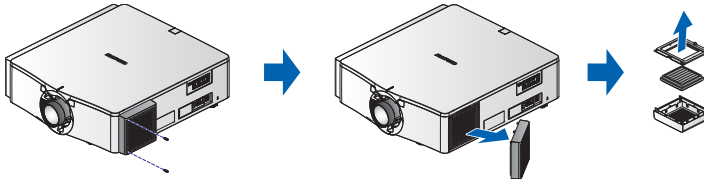

Right side filter

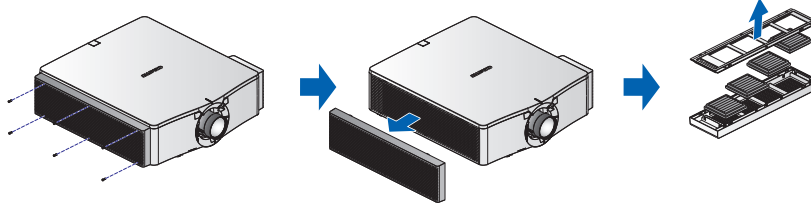

3. Remove the filter cover.
4. Remove the filter from its compartment.
5. Clean or replace the filter.

Fog filters should be replaced after each use of the projector to a maximum of 20 hours. The life of the filter is approximately 20 hours based on environmental conditions. Leave the filters in their sealed packaging until ready for use.



Do not re-use the fog filters as they clog up with oil and the projector overheats and shuts down.

Connecting to AC power

To operate the projector at full brightness, make sure the power supply meets the power requirements for HS Series 4K projectors.

To ensure safe operation, only use the AC power cord provided with the product or recommended by Christie. Connect the AC power cord to the AC inlet on the projector.

Model name	Power requirements
4K13-HS, 4K13A-HS	100-240 VAC, 50/60Hz, 11 A <ul style="list-style-type: none"> • 100-120 VAC, 50/60Hz, 11 A • 220-240 VAC, 50/60Hz, 5 A
4K22-HS, 4K22A-HS	100-240 VAC, 50/60Hz, 13.5 A <ul style="list-style-type: none"> • 100-120 VAC, 50/60Hz, 13.5 A • 220-240 VAC, 50/60Hz, 8.5 A

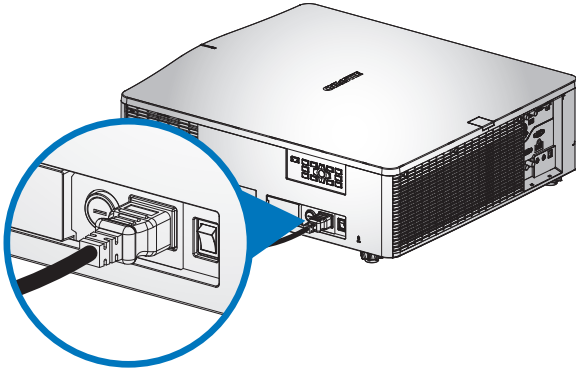

Turning on the projector

The projector cables must be securely connected before turning the power on.



Warning! If not avoided, the following could result in death or serious injury.

- Do not look into the projector lens when the laser is on. The bright light may result in permanent eye damage.
- Installing or replacing a lens must be done by a Christie qualified service technician to avoid exposure to dangerous emission levels.

1. Plug the projector in to AC power.

The Power button on the built in keypad is illuminated when the power cables are connected.

2. Ensure the lens has been installed in the projector by a Christie-qualified service technician.
3. Make sure that no one or no objects are in the beam path before turning on the projector.
4. To turn on the projector, on the IR remote keypad or on the built-in keypad press .

The status LED is green with a long blink.

5. To select an input source and turn it on, on the IR remote keypad select **INPUT**.

Available input sources are HDMI1, HDMI2, Display Port, 12G-SDI, and HDBaseT.

The projector detects the source you selected and displays the image.

6. If using the projector for the first time, select a preferred language from the Main Menu after the startup screen is displayed.

Turning off the projector

Power off the projector in preparation for inspection or maintenance.

1. To turn the projector off, on the IR remote keypad or built-in keypad select .

A warning message appears on the displayed image.

2. To confirm your selection, select  again.

If you do not press  again, the warning message disappears after three seconds and the projector remains on.

LED status indicator

LED status indicator helps identify the projector state. LEDs are defined below.

Status LED

Identify the LED state colors and meaning.

LED status	Projector state
Off	AC power is off (without AC plugged in).
Green (flashing)	Projector is starting up.
Green (solid)	System is operating normally.
Blue (flashing)	Projector is cooling down.
Blue (solid)	Projector is in standby mode.
Yellow (flashing)	A problem exists with the projector that does not cause it to shut down. Examples of warnings include: filter needs changing, one of the pumps is damaged, or a fan is operating at full speed due to over temperature of laser diode (LD) driver.
Yellow (solid)	The end user is turning off the projector while it is in a warning state.
Red (flashing)	An error with the projector exists causing it to shut down. Examples of errors include: fan failure, over temperature, wrongly installed filter, or color wheel (CW) failure.
Red (solid)	The user is turning off the projector while it is in an error state.
White (flashing)	Projector is in a flash (LAN) update state.

Shutter LED

Identify the shutter LED state colors and meaning.

LED status	Projector state
Off	Projector is on and an image is displayed. Shutter is open.
Magenta (solid)	Projector is on and the image is blank. Shutter is closed.

Setting up the projector lens

Set up the projector lens to adjust the image size, focus, and position.

Adjusting the zoom and focus

Ensure that the image reflected from the digital micromirror device (DMD) is parallel and centered with the lens and screen.

1. Display an image or test pattern that can be used to analyze image focus and geometry.
2. Select **ZOOM** on keypad or remote control.
You can also select **MENU > Configuration > Lens Settings > Zoom**.
3. Use the up and down arrow keys to zoom in or out of the image.
4. To exit the menu, select **EXIT**.
5. Select **FOCUS** on keypad or remote control.
You can also select **MENU > Configuration > Lens Settings > Focus**.
6. Use the up and down arrow keys to adjust the focus of the image.
7. To exit the menu, select **EXIT**.
8. To refine your adjusts, repeat steps 2 to 7.

Adjusting lens position

Shift the lens to the specific position.

1. Display an image or test pattern that can be used to analyze image location.
2. Select **LENS** on keypad or **LENS H/LENS V** on remote control.
You can also select **MENU > Configuration > Lens Settings > Lens Shift**.
3. Use the arrow keys to adjust the lens position.
For best lens performance, keep the shift values within the lens offset ranges. See [Calculating the lens offset](#) on page 34 for more information.
4. To exit the menu, select **EXIT**.

Resetting the lens to home position

Set the lens offset back to the home position.

1. Select **LENS** on keypad or **LENS H/LENS V** on remote control.
You can also select **MENU > Configuration > Lens Settings > Lens Calibration**.
2. Select **ENTER**.
3. To start the lens calibration, select **OK**.

Calculating the lens offset

Adjust the lens offset (shift) to align the image on the screen with half image size. To ensure optimal projector and lens performance, Christie recommends keeping the offset (shift) values within the ranges specified below.

- The vertical image offset (shift) range for the projector is up to $\pm 140\%$.
- The horizontal image offset (shift) range for the projector is up to $\pm 50\%$.
- The method for calculating lens offset complies with industry standards, with which the image offset is calculated by half image size. For example for vertical lens offset:
 - At 0% offset (or on axis), the center of the image is on the lens center, so half of the image appears above and half appears below the lens center.
 - At +100% offset, all of the image appears above the lens center.

The following show the vertical and horizontal image offsets for the HS Series 4K projectors:

- Vertical image offset: 0%

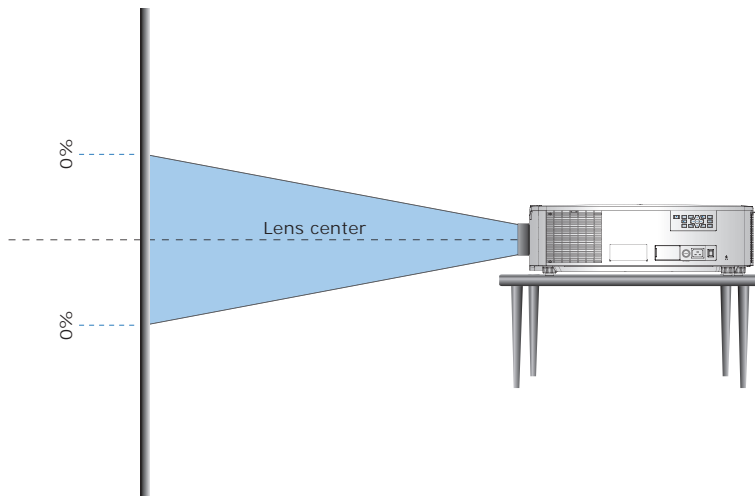

- 4K Vertical image offset: $\pm 140\%$

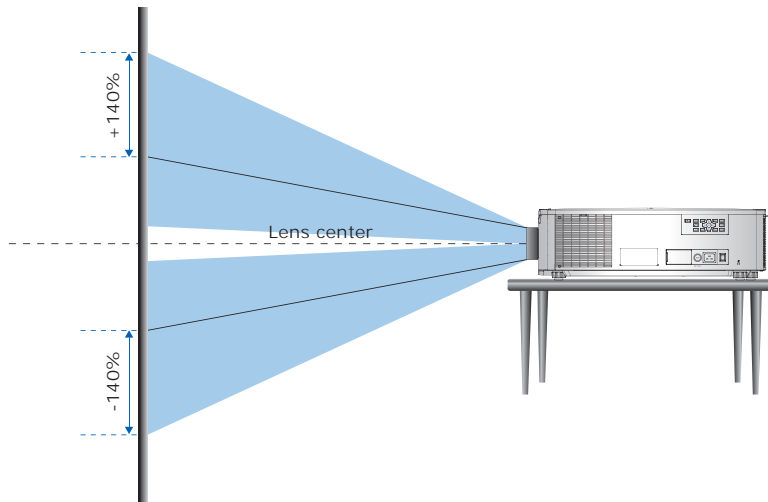

- Horizontal image offset: $\pm 50\%$

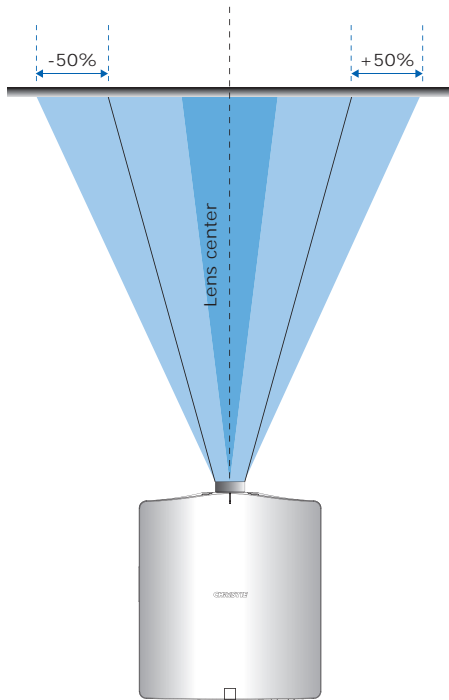

Adjusting boresight

The boresight adjustment turns the lens holder to remove the tilt between the lens and DMD to make the image clear, crisp, and sharp. To perform boresight adjustment, use an M4 Allen key to adjust the three boresight set screws on the lens holder.

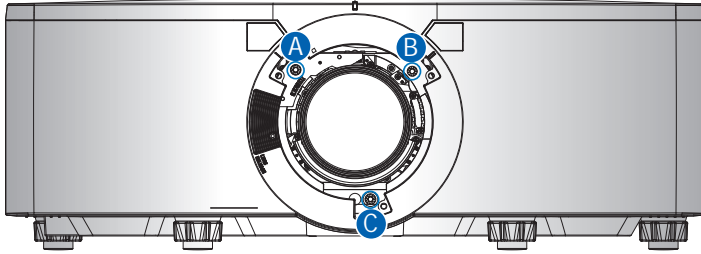

Items	Description
A, B, C	Boresight set screws <ul style="list-style-type: none"> To tighten the set screws, turn counterclockwise. To loosen the set screws, turn clockwise.



Christie recommends adjusting the set screws 1/4 turns each time. The balance between the set screws is subtle and a small adjustment can make an obvious change on the screen.

To perform boresight adjustment, complete the following steps:

1. Project a focus test pattern.

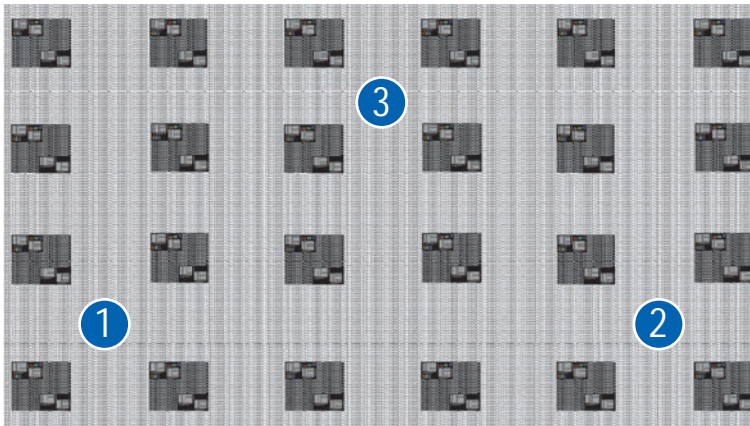

2. To optimize the focus of position 1 on the screen, press **FOCUS ▲** or **▼** key.
3. Once position 1 is in focus, check position 2. If position 2 is not in focus, use the **FOCUS ▲** or **▼** key to bring position 2 into focus on the screen.
 - If selecting **FOCUS ▲** key results in position 2 coming into focus, turn set screw A clockwise.

- If selecting **FOCUS ▼** key results in position 2 coming into focus, turn set screw A counterclockwise.
4. Refocus position 1 and check if position 2 is also in focus. If not, repeat step 3 and 4 until both position 1 and 2 are in focus.
 5. To optimize the focus of position 3 on the screen, turn set screw C clockwise or counterclockwise.
 - If selecting **FOCUS ▲** key results in position 3 coming into focus, turn set screw C clockwise.
 - If selecting **FOCUS ▼** key results in position 3 coming into focus, turn set screw C counterclockwise.
 6. Repeat from step 2 until the projected focus pattern is as sharp as possible in the center, left, right, top, and bottom of the screen.
 7. If the projector is still not in focus, reset the set screw position:
 - a. Turn the set screws counterclockwise until tight.
 - b. Turn the set screws 1.5 turns in the clockwise direction back to their factory default setting.
 - c. Check that the alignment of the set screws matches what is shown in the image above.

Connecting to devices

This section covers the information on connecting the HS Series 4K projector to a computer and video equipment.

Connecting to a computer

Learn what cables/connectors can be used to connect to various devices.

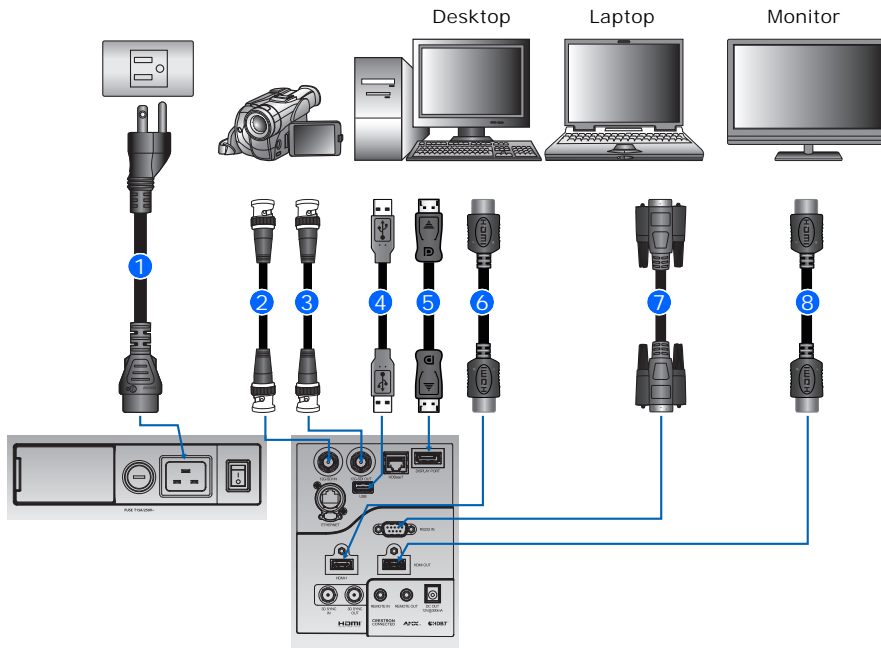

ID	Connector name	ID	Connector name
1	Power cord	5	DisplayPort cable
2	12G-SDI in with BNC cable + camcorder	6	HDMI cable
3	12G-SDI out with BNC cable + camcorder	7	RS232 cable
4	USB type A cable	8	HDMI cable

Connecting to video equipment

Learn what cable/connectors may be used to connect to various video sources.

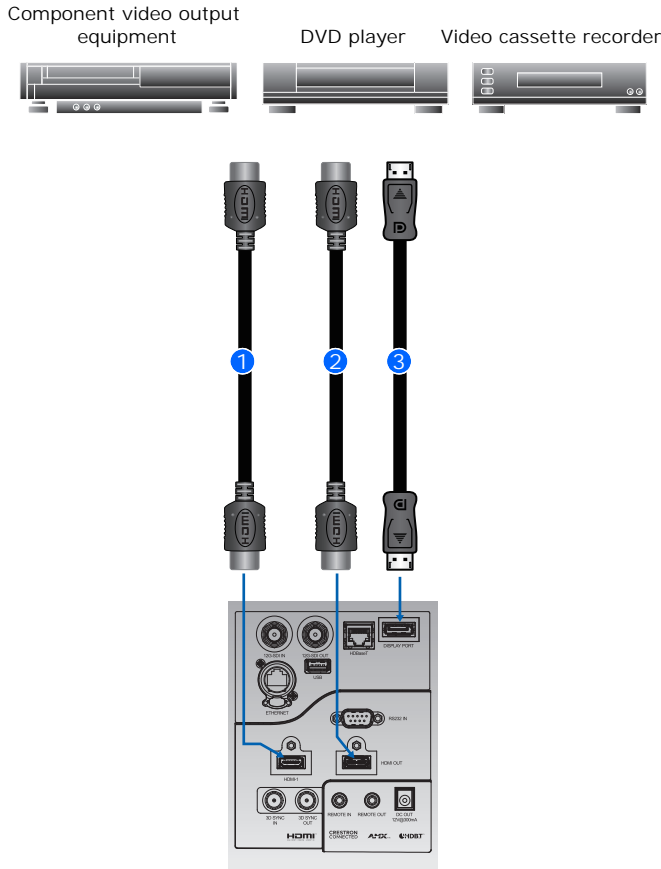

ID	Connector name	ID	Connector name
1	HDMI cable	3	DisplayPort cable
2	HDMI cable		



- After connecting the projector to an input device, the projector automatically detects the input source. You can also select an input source by selecting **INPUT**.
- Due to the difference in applications for each country, the accessories required in some regions may differ from those shown.
- The diagrams are for illustrative purposes only and do not indicate these accessories are supplied with the projector.

Signal connectivity specifications

Identify the signal connectivity specifications for the HS series 4K projector.

The list of formats listed below are not exhaustive and other formats may be supported. For more information, contact Christie Technical Support.

HDMI video formats

Identify the video formats for the HDMI input.

Signal type	Format	Hres	Vres	Frame rate (Hz)	Sampling	Bit-depth
PC	1024x768	1024	768	60,75,85,120	RGB/4:4:4/4:2:2	8/10/12bpc
	1152x864	1152	864	60,70,75,85	RGB/4:4:4/4:2:2	8/10/12bpc
	1152x870	1152	870	75	RGB/4:4:4/4:2:2	8/10/12bpc
	1280x720	1280	720	50,60,75,85,120	RGB/4:4:4/4:2:2	8/10/12bpc
	1280x768	1280	768	60,75,85	RGB/4:4:4/4:2:2	8/10/12bpc
	1280x800	1280	800	50,60,75,85	RGB/4:4:4/4:2:2	8/10/12bpc
	1280x960	1280	960	50,60,75,85	RGB/4:4:4/4:2:2	8/10/12bpc
	1280x1024	1280	1024	50,60,75,85	RGB/4:4:4/4:2:2	8/10/12bpc
	1360x768	1360	768	50,60,75,85	RGB/4:4:4/4:2:2	8/10/12bpc
	1368x768	1368	768	60	RGB/4:4:4/4:2:2	8/10/12bpc
	1400x1050	1400	1050	50,60,75	RGB/4:4:4/4:2:2	8/10/12bpc
	1440x900	1440	900	60,75	RGB/4:4:4/4:2:2	8/10/12bpc
	1600x900	1600	900	60	RGB/4:4:4/4:2:2	8/10/12bpc
	1600x1200	1600	1200	60	RGB/4:4:4/4:2:2	8/10/12bpc
	1920x1080	1920	1080	50,60	RGB/4:4:4/4:2:2	8/10/12bpc
1920x1200RB	1920	1920	50,60	RGB/4:4:4/4:2:2	8/10/12bpc	

Signal type	Format	Hres	Vres	Frame rate (Hz)	Sampling	Bit-depth
HDTV	1080i			25,29,30	RGB/4:4:4/4:2:2	8/10/12bpc
	720p			50,59,60	RGB/4:4:4/4:2:2	8/10/12bpc
	1080p			23,24,25,29,30,50,59,60	RGB/4:4:4/4:2:2	8/10/12bpc
Mandatory 3D	Frame Packing 1080p			24	RGB/4:4:4/4:2:2	8/10/12bpc
	Frame Packing 720p			50,60	RGB/4:4:4/4:2:2	8/10/12bpc
	Top and Bottom 720p			50,60	RGB/4:4:4/4:2:2	8/10/12bpc
	Top and Bottom 1080p			24	RGB/4:4:4/4:2:2	8/10/12bpc
	Side by Side 1080i			25,30	RGB/4:4:4/4:2:2	8/10/12bpc
Frame Sequential 3D	1024x768			120	RGB/4:4:4	8bpc
	1280x720			120	RGB/4:4:4	8bpc
	1920x1080			120	RGB/4:4:4	8bpc
	1920x1080			60	RGB/4:4:4	8bpc
	1920x1200RB			60	RGB/4:4:4	8bpc
4K	3840x2160	3840	2160	23,24,25,29,30,50,59,60	RGB/4:4:4	8bpc
	4096x2160	4096	2160	23,24,25,29,30,50,59,60	RGB/4:4:4	8bpc
Dual Pipe	1080p			60	RGB/4:4:4/4:2:2	8/10/12bpc
4K 3D (Passive 3D only)	3840x2160			60	RGB/4:4:4	8bpc
4K 3D Dual Pipe (Passive 3D only)	3840x2160			60	RGB/4:4:4	8bpc

DisplayPort video formats

Identify the video formats for the DisplayPort input.

Signal type	Format	Hres	Vres	Frame rate (Hz)	Sampling	Bit-depth
PC	1024x768	1024	768	60,75,85,120	RGB/4:4:4/4:2:2	8/10/12bpc
	1152x864	1152	864	60,70,75,85	RGB/4:4:4/4:2:2	8/10/12bpc
	1152x870	1152	870	75	RGB/4:4:4/4:2:2	8/10/12bpc
	1280x720	1280	720	50,60,75,85,120	RGB/4:4:4/4:2:2	8/10/12bpc
	1280x768	1280	768	60,75,85	RGB/4:4:4/4:2:2	8/10/12bpc
	1280x800	1280	800	50,60,75,85	RGB/4:4:4/4:2:2	8/10/12bpc
	1280x960	1280	960	50,60,75,85	RGB/4:4:4/4:2:2	8/10/12bpc
	1280x1024	1280	1024	50,60,75,85	RGB/4:4:4/4:2:2	8/10/12bpc
	1360x768	1360	768	50,60,75,85	RGB/4:4:4/4:2:2	8/10/12bpc
	1368x768	1368	768	60	RGB/4:4:4/4:2:2	8/10/12bpc
	1400x1050	1400	1050	50,60,75	RGB/4:4:4/4:2:2	8/10/12bpc
	1440x900	1440	900	60,75	RGB/4:4:4/4:2:2	8/10/12bpc
	1600x900	1600	900	60	RGB/4:4:4/4:2:2	8/10/12bpc
	1600x1200	1600	1200	60	RGB/4:4:4/4:2:2	8/10/12bpc
	1920x1080	1920	1080	50,60	RGB/4:4:4/4:2:2	8/10/12bpc
1920x1200RB	1920	1920	50,60	RGB/4:4:4/4:2:2	8/10/12bpc	
HDTV	1080i			25,29,30	RGB/4:4:4/4:2:2	8/10/12bpc
	720p			50,59,60	RGB/4:4:4/4:2:2	8/10/12bpc
	1080p			23,24,25,29,30,50,59,60	RGB/4:4:4/4:2:2	8/10/12bpc
Frame Sequential 3D	1024x768			120	RGB/4:4:4	8bpc
	1280x720			120	RGB/4:4:4	8bpc
	1920x1080			120	RGB/4:4:4	8bpc
	1920x1080			60	RGB/4:4:4	8bpc
	1920x1200RB			60	RGB/4:4:4	8bpc
4K	3840x2160	3840	2160	23,24,25,29,30,50,59,60	RGB/4:4:4	8bpc
	4096x2160	4096	2160	23,24,25,29,30,50,59,60	RGB/4:4:4	8bpc
4K 3D (Passive 3D only)	3840x2160			60	RGB/4:4:4	8bpc
4K 3D Dual Pipe (Passive 3D only)	3840x2160			60	RGB/4:4:4	8bpc

HDBaseT video formats

Identify the video formats for the HDBaseT input.

Signal type	Format	Hres	Vres	Frame rate (Hz)	Sampling	Bit-depth
PC	1024x768	1024	768	60,75,85,120	RGB/4:4:4/4:2:2	8bpc
	1152x864	1152	864	60,70,75,85	RGB/4:4:4/4:2:2	8bpc
	1152x870	1152	870	75	RGB/4:4:4/4:2:2	8bpc
	1280x720	1280	720	50,60,75,85,120	RGB/4:4:4/4:2:2	8bpc
	1280x768	1280	768	60,75,85	R GB/4:4:4/4:2:2	8bpc
	1280x800	1280	800	50,60,75,85	RGB/4:4:4/4:2:2	8bpc
	1280x960	1280	960	50,60,75,85	RGB/4:4:4/4:2:2	8bpc
	1280x1024	1280	1024	50,60,75,85	RGB/4:4:4/4:2:2	8bpc
	1360x768	1360	768	50,60,75,85	RGB/4:4:4/4:2:2	8bpc
	1368x768	1368	768	60	RGB/4:4:4/4:2:2	8bpc
	1400x1050	1400	1050	50,60,75	RGB/4:4:4/4:2:2	8bpc
	1440x900	1440	900	60,75	RGB/4:4:4/4:2:2	8bpc
	1600x900	1600	900	60	RGB/4:4:4/4:2:2	8bpc
	1600x1200	1600	1200	60	RGB/4:4:4/4:2:2	8bpc
	1920x1080	1920	1080	50,60	RGB/4:4:4/4:2:2	8bpc
1920x1200RB	1920	1920	50,60	RGB/4:4:4/4:2:2	8bpc	
HDTV	1080i			25,29,30	RGB/4:4:4/4:2:2	8bpc
	720p			50,59,60	RGB/4:4:4/4:2:2	8bpc
	1080p			23,24,25,29,30,50,59,60	RGB/4:4:4/4:2:2	8bpc
Frame Sequential 3D	1024x768			120	RGB/4:4:4	8bpc
	1280x720			120	RGB/4:4:4	8bpc
	1920x1080			60	RGB/4:4:4	8bpc
	1920x1200RB			60	RGB/4:4:4	8bpc
4K	3840x2160	3840	2160	23,24,25,29,30	RGB/4:4:4	8bpc
	4096x2160	4096	2160	23,24,25,29,30	RGB/4:4:4	8bpc
4K 3D (Passive 3D only)	3840x2160			60	RGB/4:4:4	8bpc
4K 3D Dual Pipe (Passive 3D only)	3840x2160			60	RGB/4:4:4	8bpc

12G-SDI video formats

Identify the video formats for the 12G-SDI input.

Signal type	Format	Hres	Vres	Frame rate (Hz)	Sampling	Bit-depth
HD-SDI	720p			50,59,60	4:2:2	10 bit
	1080i			25,29,30	4:2:2	10 bit
	1080p			23,24,25,29,30	4:2:2	10 bit
	1080sF			23,24,25,29,30	4:2:2	10 bit
3GA-SDI	1080p			50,59,60	4:2:2	10 bit
12G-SDI	3840x2160			24,25,30,50,60	4:2:2	10 bit

Picture-in-picture/picture-by-picture (PIP/PBP) compatibility

The following table details the picture-in-picture/picture-by-picture (PIP/PBP) compatibility.

PIP/PBP matrix	DisplayPort	HDMI1	HDMI2	12G-SDI	HDBaseT
DisplayPort		•	•	•	•
HDMI1	•		•	•	•
HDMI2	•	•		•	•
12G-SDI	•	•	•		•
HDBaseT	•	•	•	•	

- Dot (•): PIP/PBP combinations are enabled.

Regulatory

This product conforms to the following regulations related to product safety, environmental requirements and electromagnetic compatibility (EMC).

Safety

- IEC 62368-1:2018 - Audio/Video, Information And Communication Technology Equipment - Part 1: Safety Requirements
- EN/BS 62368-1:2014 + A11: 2017 - Audio/Video, Information And Communication Technology Equipment - Part 1: Safety Requirements
- UL 62368-1:2018 - Audio/Video, Information And Communication Technology Equipment - Part 1: Safety Requirements
- CSA CAN/CSA-22.2 No. 62368-1:2018 - Audio/Video, Information And Communication Technology Equipment - Part 1: Safety Requirements

Laser safety

- IEC/EN/BS 62471-5 - Photobiological safety of lamps and lamp systems - Part 5: Image projectors
- IEC/EN/BS 60825-1: 2014 - Safety of Laser Products - Part 1: Equipment Classification and Requirements

Electro-magnetic compatibility

Emissions

- FCC CFR47, Part 15, Subpart B, Class A - Unintentional Radiators
- CAN ICES-003 (A) / NMB-003 (A)
- CISPR 32/EN/BS55032, Class A – Electromagnetic Compatibility of Multimedia Equipment – Emission Requirements
- IEC 61000-3-2/EN/BS61000-3-2 - Limits for Harmonic Current Emissions

- IEC 61000-3-3/EN/BS61000-3-3 - Limitations of Voltage Changes, Voltage Fluctuations, and Flicker

Immunity

- CISPR 35/EN/BS55035 Electromagnetic compatibility of multimedia equipment - Immunity requirements

California law on security

- California Law Requiring Internet Connected Devices To Include Reasonable Security Features (California Civil Code Section 1798.91.04)

Environmental

- EU Directive (2011/65/EU) on the restriction of the uses of certain hazardous substances (RoHS) in electrical and electronic equipment and the applicable official amendment(s)
- EU Directive (2012/19/EU) on waste and electrical and electronic equipment (WEEE) and the applicable official amendment(s)
- Regulation (EC) No 1907/2006 concerning the Registration, Evaluation, Authorization and Restriction of Chemicals (REACH) and the applicable official amendment(s)
- China Ministry of Information Industry Order No.39 (02/2006) on the control of pollution caused by electronic information products, hazardous substances concentration limits (SJ/T11363-2006), and the applicable product marking requirement (SJ/T11364-2006)

